



CARBURETTOR Tillotson HL-334B



PHOTO OF ADJUSTING SIDE

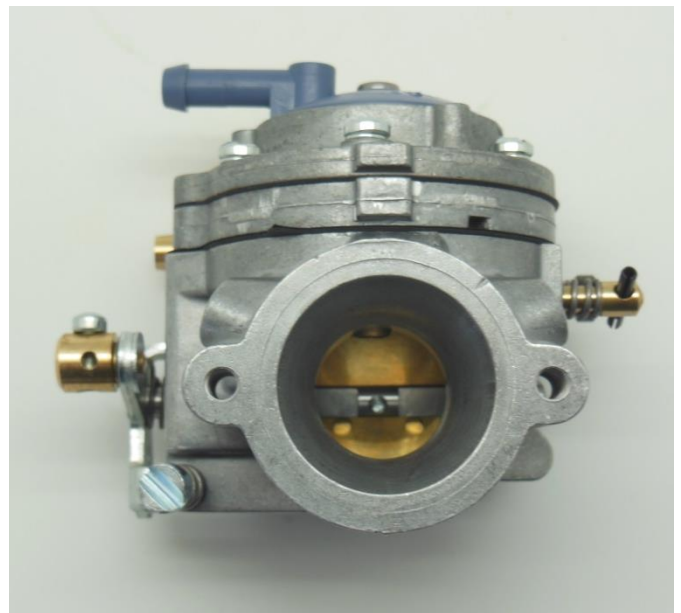
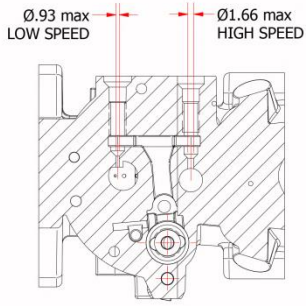

PHOTO OF INLET SIDE

Manufacturer	TILLOTSON LTD.
Make	TILLOTSON
Model	HL-334B

SECTION VIEW



SECTION B-B

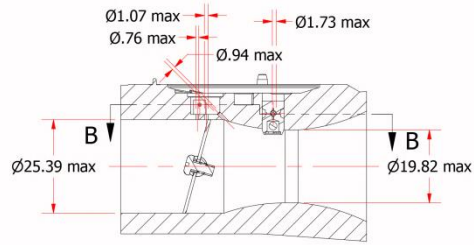

SECTION A-A

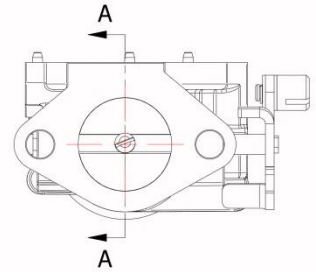

THROTTLE LEVER

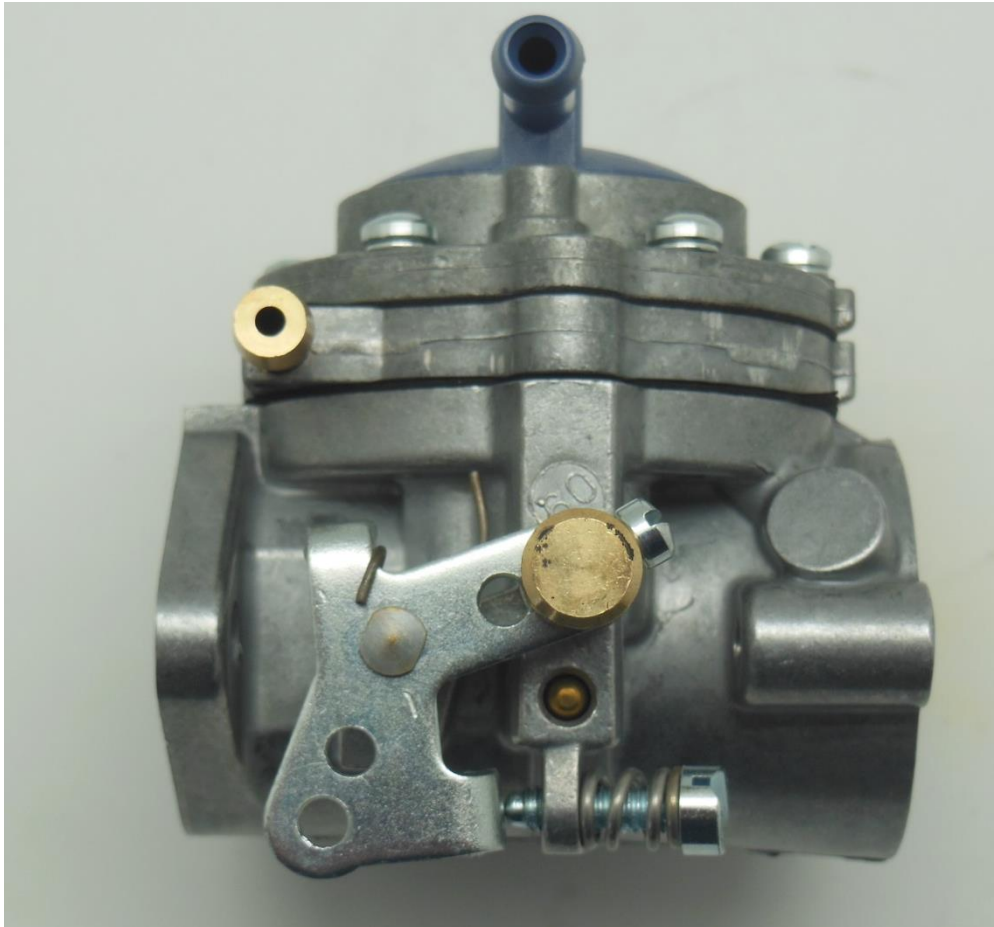

CARBURETTOR DESCRIPTION AND SKETCH OF PARTS

ITEM	PART NO.	DESCRIPTION	QTY
9	+ * 16-B217	DIAPHRAGM GASKET	1
10	+ * 237-600	DIAPHRAGM	1
11	91-1018	DIAPHRAGM COVER	1
13	+ * 16-B223	FUEL PUMP GASKET	1
14	+ * 237-141	FUEL PUMP DIAPHRAGM	1
15	141-89	FUEL PUMP BODY	1
16	15C-51	FUEL PUMP BODY SCREW	6
17	95 - 170	FUEL STRAINER SCREEN	1
18	+ * 16-B205	FUEL STRAINER COVER GASKET	1
19	91-A351	FUEL STRAINER COVER	1
20	15-B313	FUEL STRAINER COVER RETAINING SCREW	1
21A	43-388	IDLE MIXTURE SCREW	1
21B	24-B449	IDLE MIXTURE SCREW SPRING	1
21C	78A-256	IDLE MIXTURE SCREW WASHER	1
21D	44-270	IDLE MIXTURE SCREW PACKING	1
25	* 155A-27	INLET CONTROL LEVER	1
26	15-B329	FULCRUM LEVER SCREW	1
26A	32-79	FULCRUM LEVER PIN	1
27	* 233-710P	INLET NEEDLE & SEAT SET	1
28	16-B199	INLET SEAT GASKET	1
29	24-B299	INLET TENSION SPRING	1
30A	43-967	HIGH SPEED MIXTURE SCREW	1
30B	24B-449	HIGH SPEED MIXTURE SCREW SPRING	1
30C	78A256	HIGH SPEED MIXTURE SCREW WASHER	1
30D	44-270	HIGH SPEED MIXTURE SCREW PACKING	1
33	29-224	THROTTLE SHAFT CLIP	1
35	15-C19	THROTTLE SHAFT CLIP RETAINING SCREW	1
36	24-B381	THROTTLE RETURN SPRING	1
37	14-407	THROTTLE SHUTTER	1
38	15-C29	THROTTLE SHUTTER SCREW	1
42	13-B76	THROTTLE SHAFT	1
43	13- 2034	THROTTLE LEVER ASSEMBLY	1
51	363-503	MAIN NOZZLE	1
52	179-55	WELCH PLUG	1
57	15-C19	LIMITER SCREW	1
58	24-B131	LIMITER SPRING	1

* INDICATES CONTENTS OF REPAIR KIT
 + * INDICATES CONTENTS OF DIAPHRAGM & GASKET SET

HL-334B

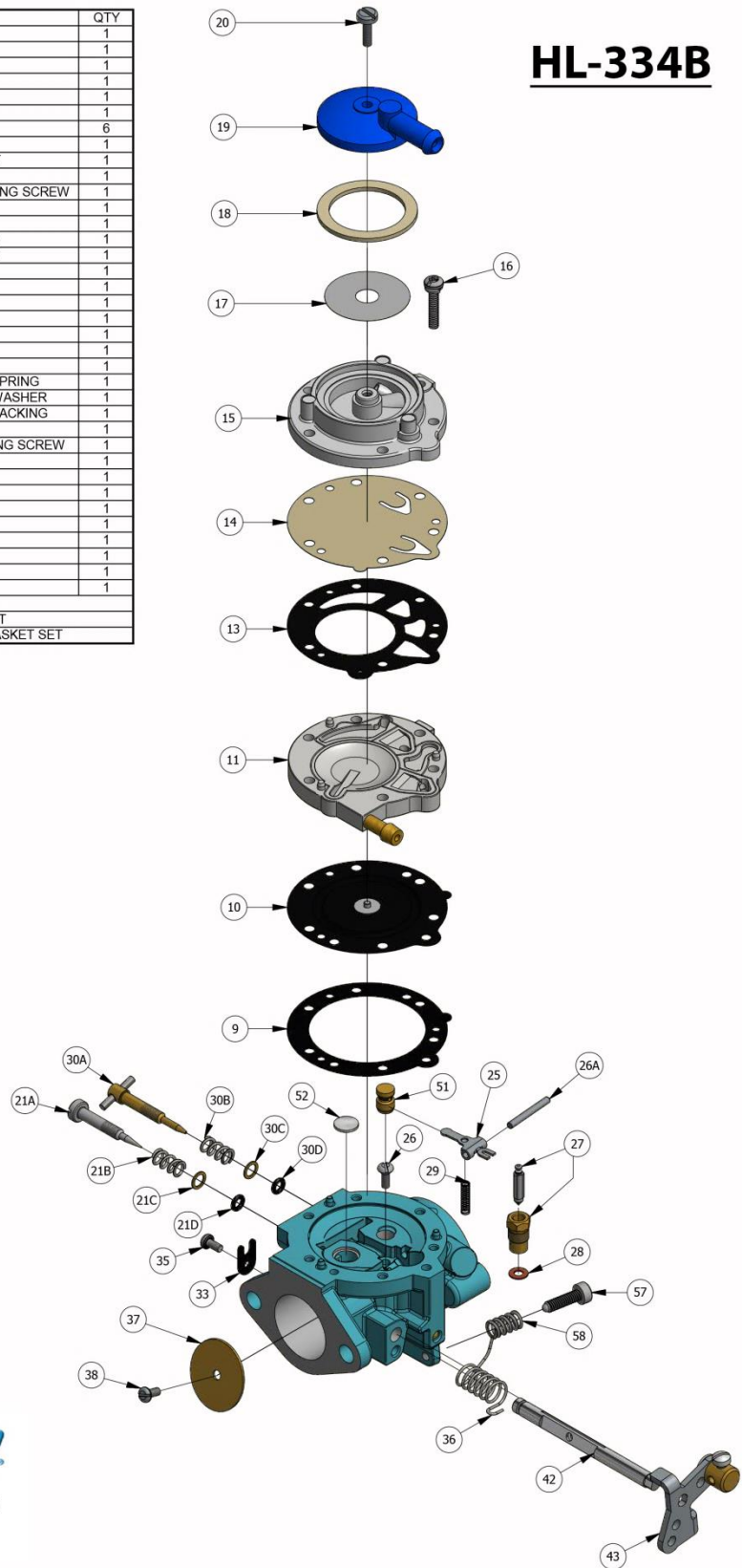

Clash Industrial Estate - Tralee - Ireland
www.tillotson-racing.com

PARTS OF CARBURETTOR

REF.9 - P. N°16-B217
DIAPHRAGM GASKET



Thickness = 0.5 ± 0.1 mm

REF.13 - P. N° 16-B223
PUMP DIAPHRAGM GASKET



Thickness = 0.5 ± 0.1 mm

REF.10 - P. N°237-600
DIAPHRAGM

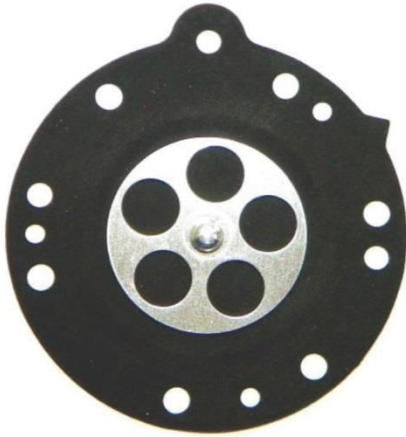

Thickness = 0.13 ± 0.07 mm

REF.14 - P. N°237-141
PUMP DIAPHRAGM



Thickness = 0.10 ± 0.063 mm

REF.11 - P. N° 91-1018
DIAPHRAGM COVER

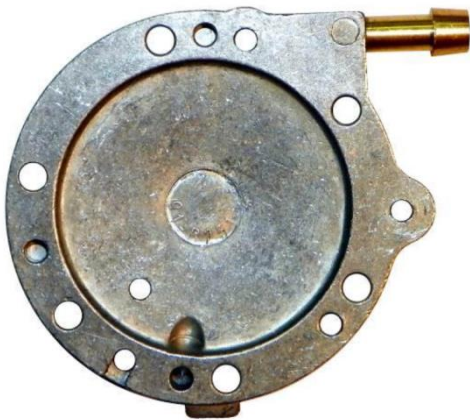

Thickness = 6.75 ± 0.15 mm

REF.15 - P. N° 141-89
PUMP COVER



Thickness = 12.5 ± 0.15 mm

REF.37 - P. N° 14-407
THROTTLE SHUTTER

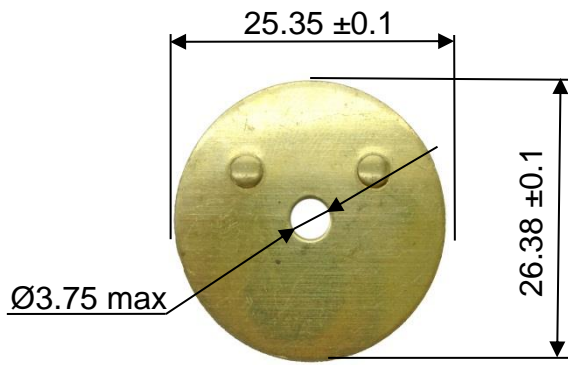

Thickness = 0.81 ± 0.1 mm

REF.27 - P. N° 233-710P
SEAT + NEEDLE

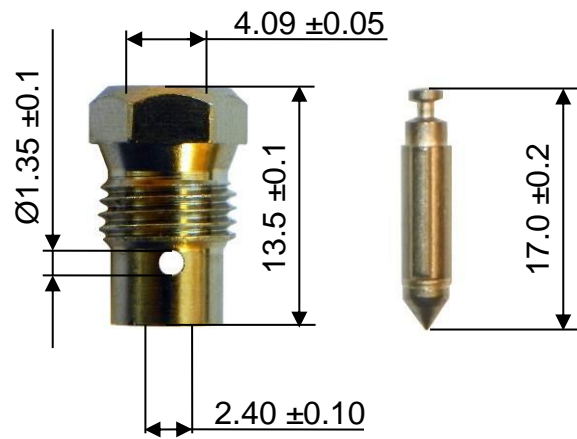

REF.21A - P. N° 43-388
NEEDLE LOW SPEED



REF.30A - P. N° 43-967
NEEDLE HIGH SPEED

