

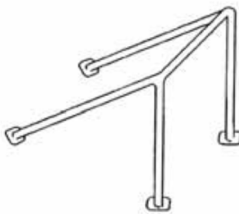

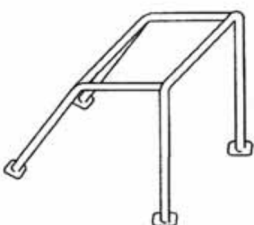
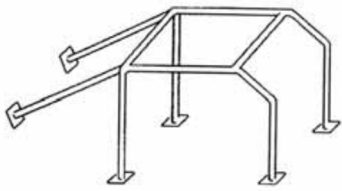
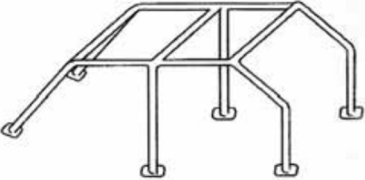

Apêndice V
 ao "ANEXO K" do CDI

Desenhos com referência ao Artigo 5.13 (Estrutura anti-capotamento de proteção - ROPS) e/ou ao "Apêndice VI"

Data de publicação da versão original pela FIA	Data de aplicação
18.12.2020	01.01.2021

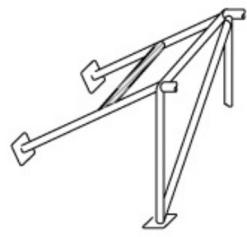
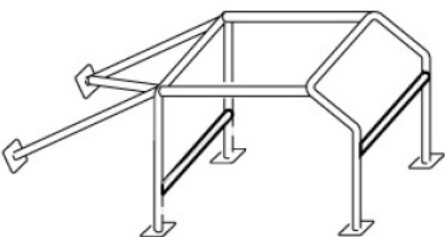
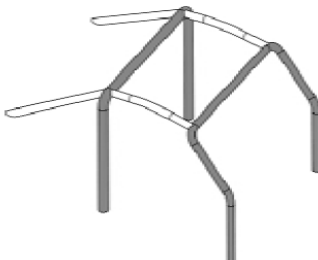
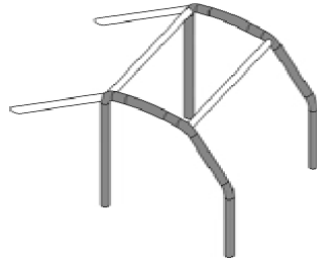
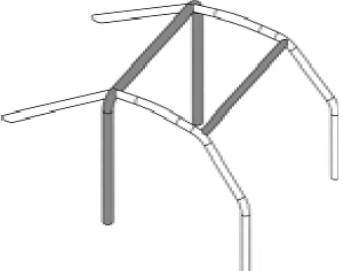
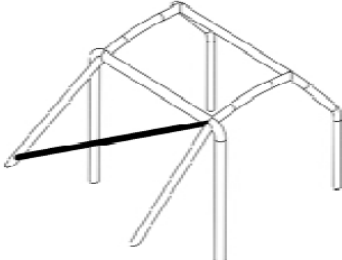
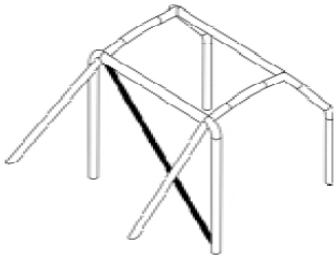
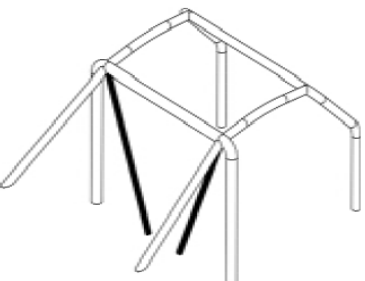
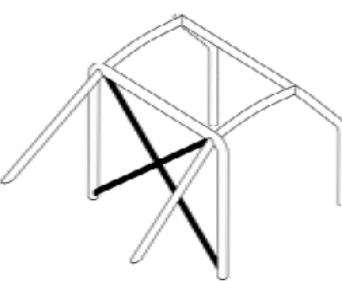
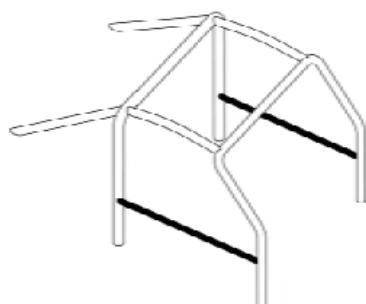
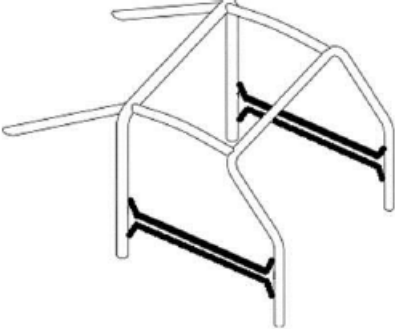
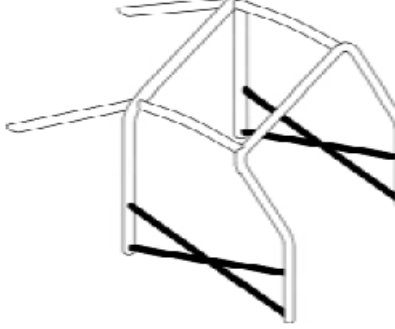
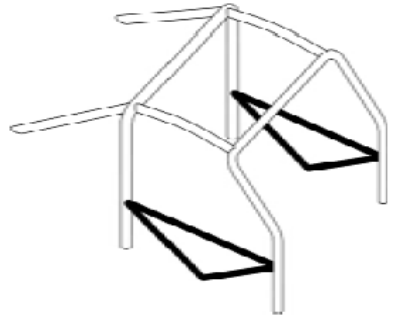
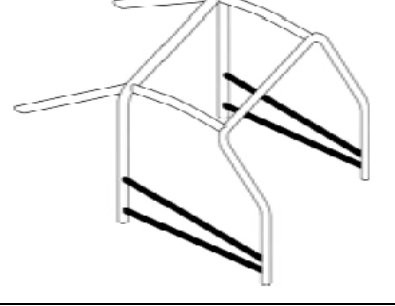
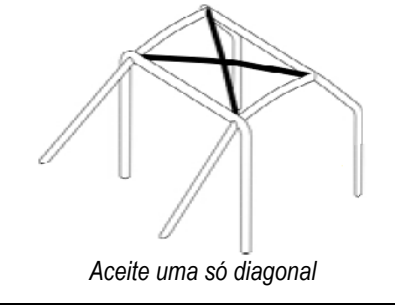
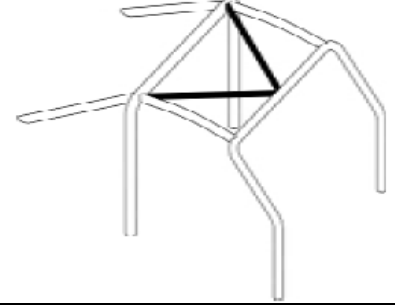
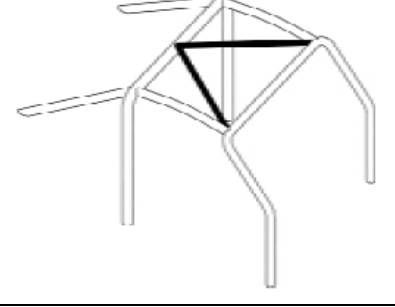
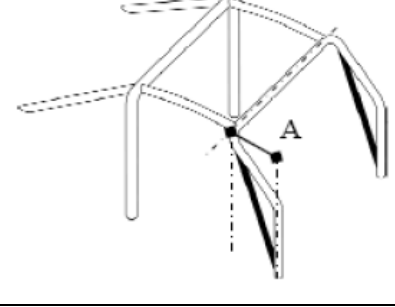
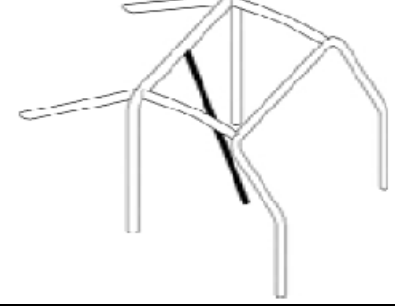
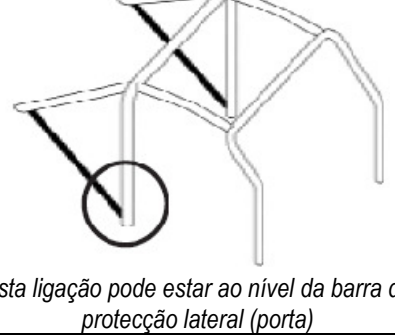
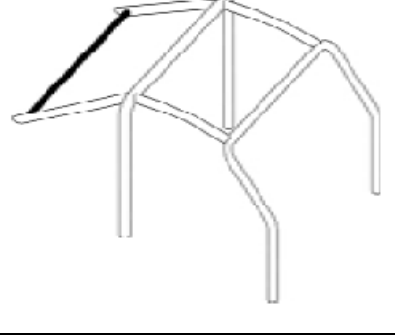
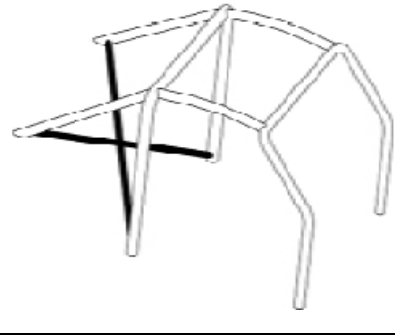
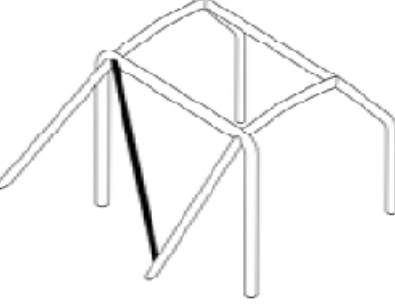
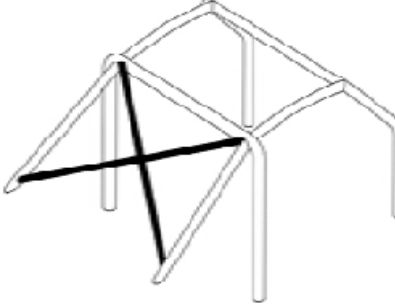
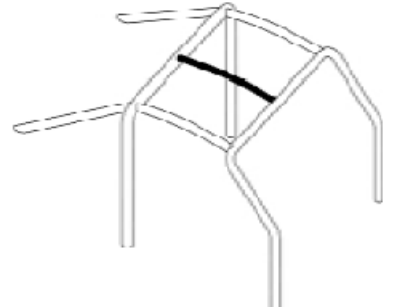
K-1 	K-2 	K-3 
K-4 	K-5 	K-6 
K-7 	K-8 	K-9 
K-10 	K-11 	K-12 
K-13 	K-14 	K-15 

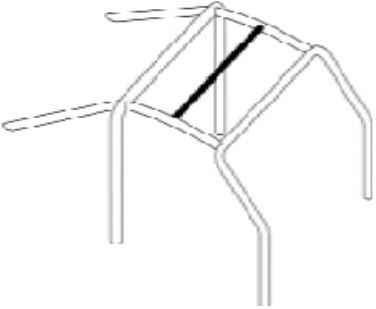
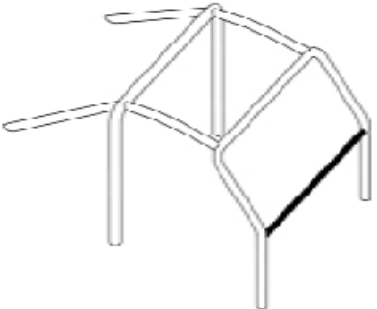
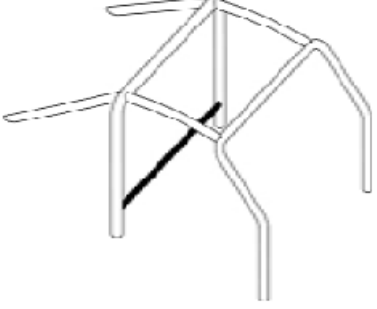
<p>K-15 A</p> 	<p>K-16</p> 	<p>K-17</p> 
<p>K-18</p> 	<p>K-19</p>  <p><i>Aceite uma só diagonal</i></p>	<p>K-20</p> 
<p>K-21</p> 	<p>K-22</p> 	<p>K-23</p> 
<p>K-24</p>  <p><i>Esta ligação pode estar ao nível da barra de protecção lateral (porta)</i></p>	<p>K-25</p> 	<p>K-26</p> 
<p>K-27</p> 	<p>K-28</p> 	<p>K-29</p> 

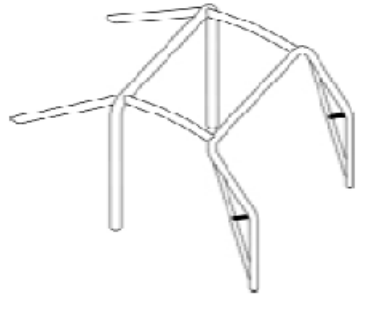
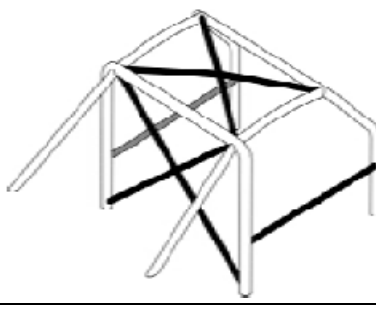
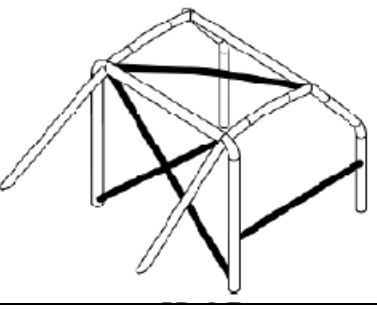
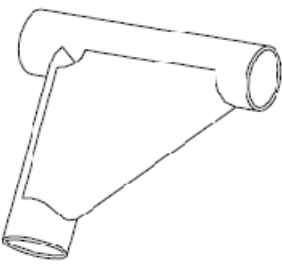
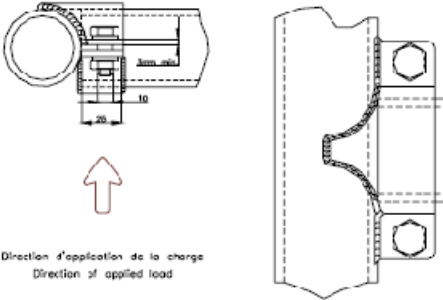
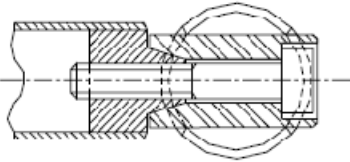
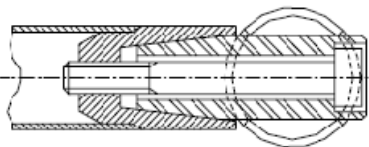
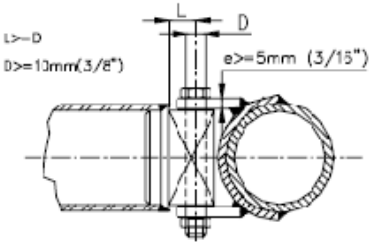
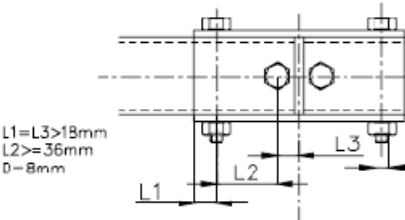
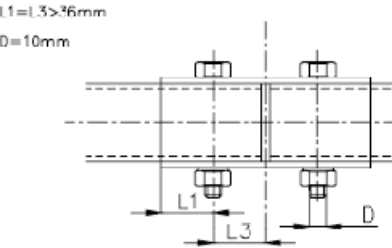
<p>K-30</p> 	<p>K-31</p> 	<p>K-32</p> 
<p>K-33</p> 	<p>K-34</p> 	<p>K-35</p> 
<p>K-36</p> 	<p>K-37</p> 	<p>K-38</p> 
<p>K-39</p>  <p>Direction d\'application de la charge Direction of applied load</p>	<p>K-40</p> 	<p>K-41</p> 
<p>K-42</p>  <p>$L > D$ $D \geq 13\text{mm} (3/8")$ $e \geq 5\text{mm} (3/16")$</p>	<p>K-43</p>  <p>$L1 = L3 > 18\text{mm}$ $L2 \geq 36\text{mm}$ $D = 8\text{mm}$</p>	<p>K-44</p>  <p>$L1 = L3 > 26\text{mm}$ $D = 10\text{mm}$</p>

K-45

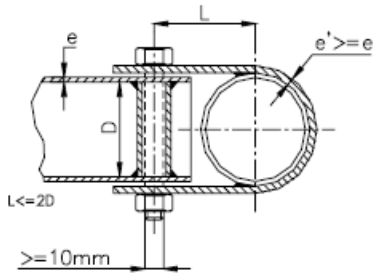

"L" deve ser mínimo. A largura da pata deve ser superior a 25mm

K-46

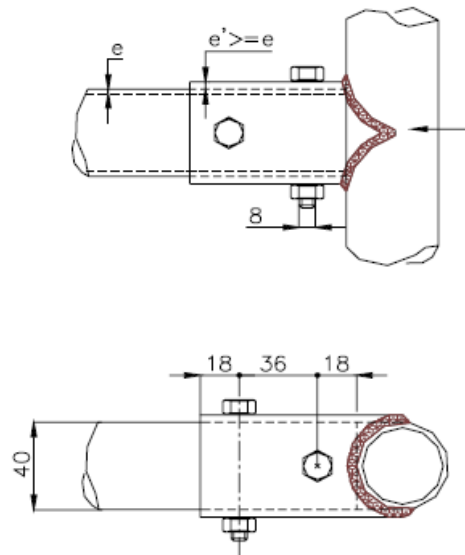

K-47

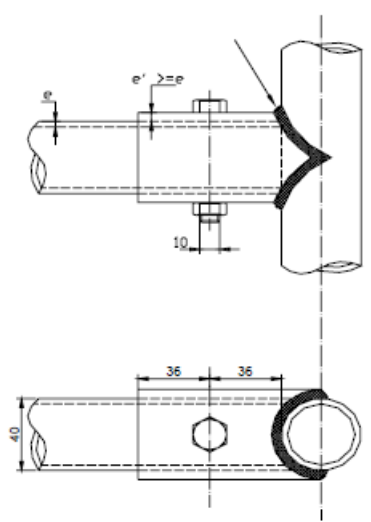

K-48

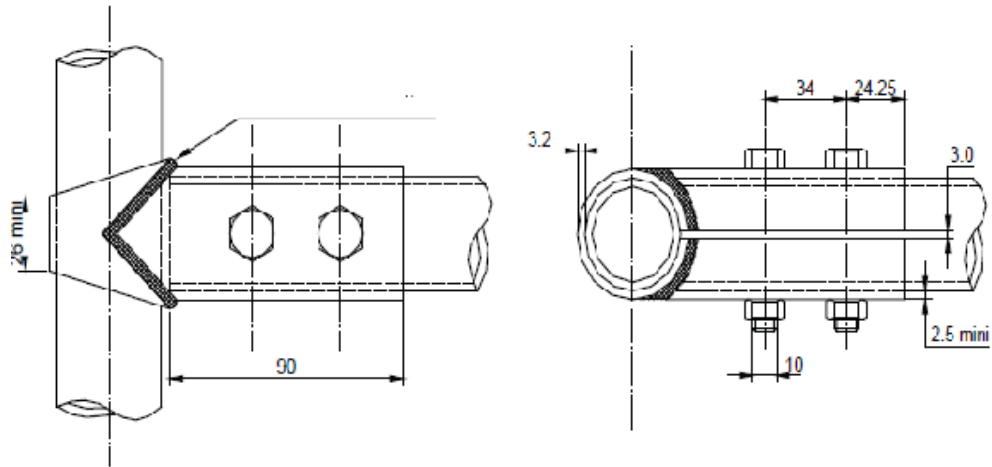

K-49

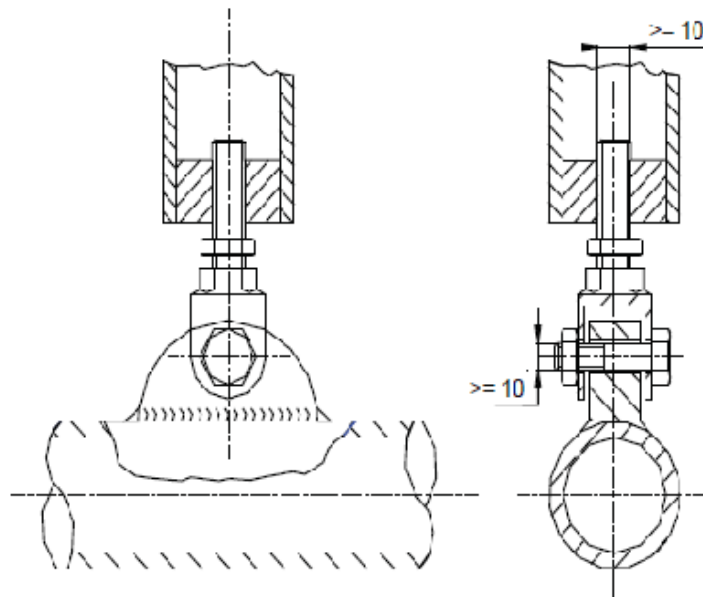

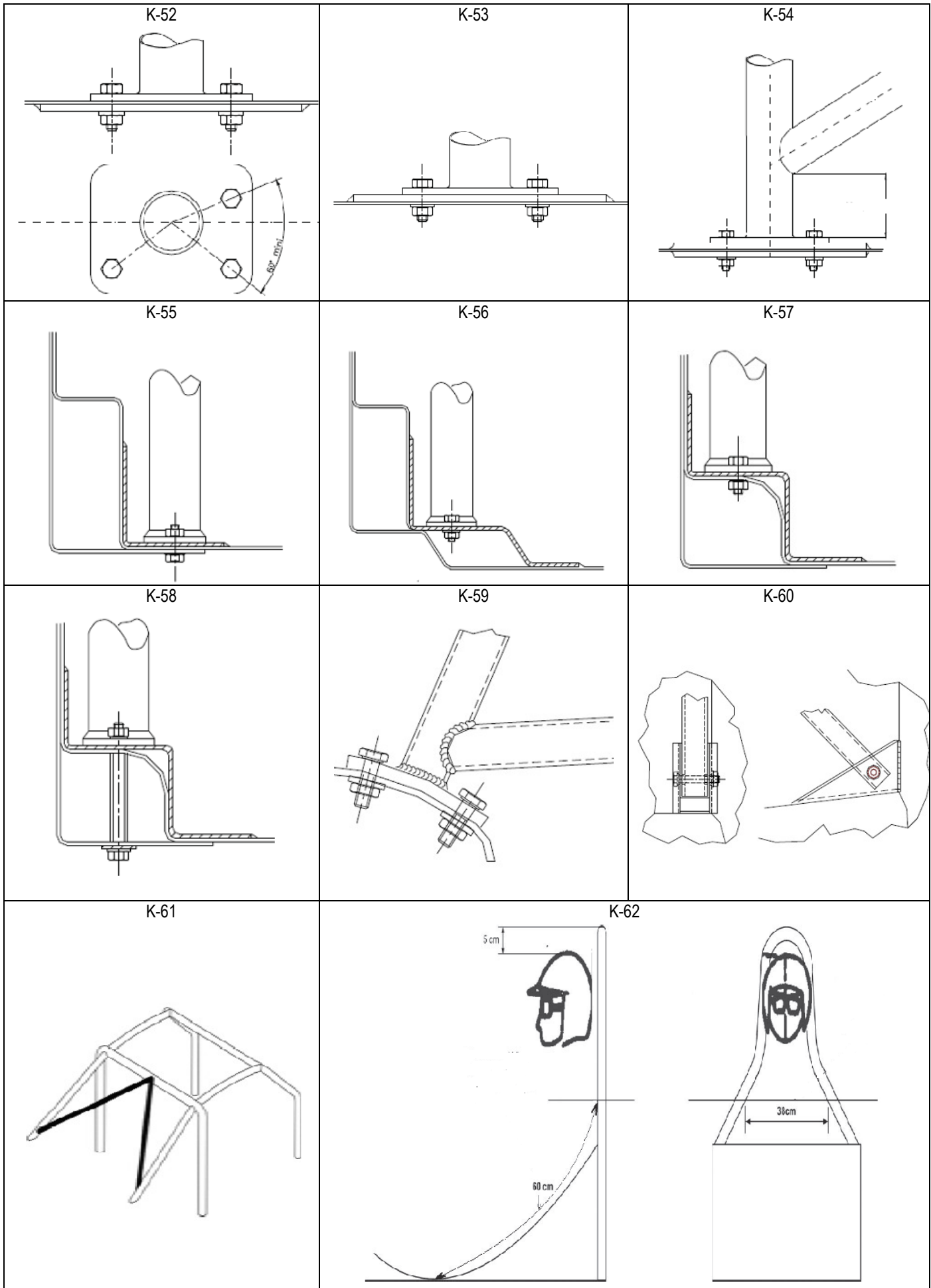

K-63

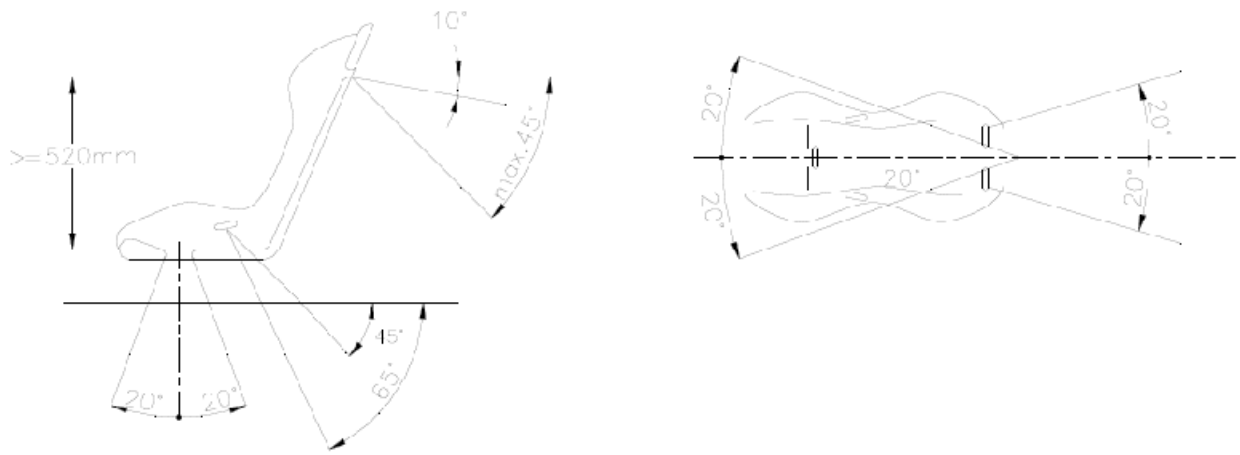

K-64

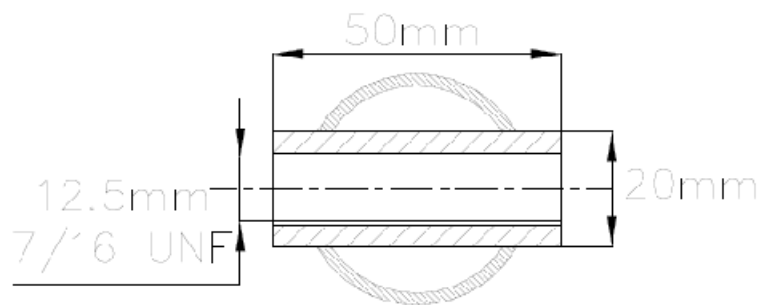

K-65

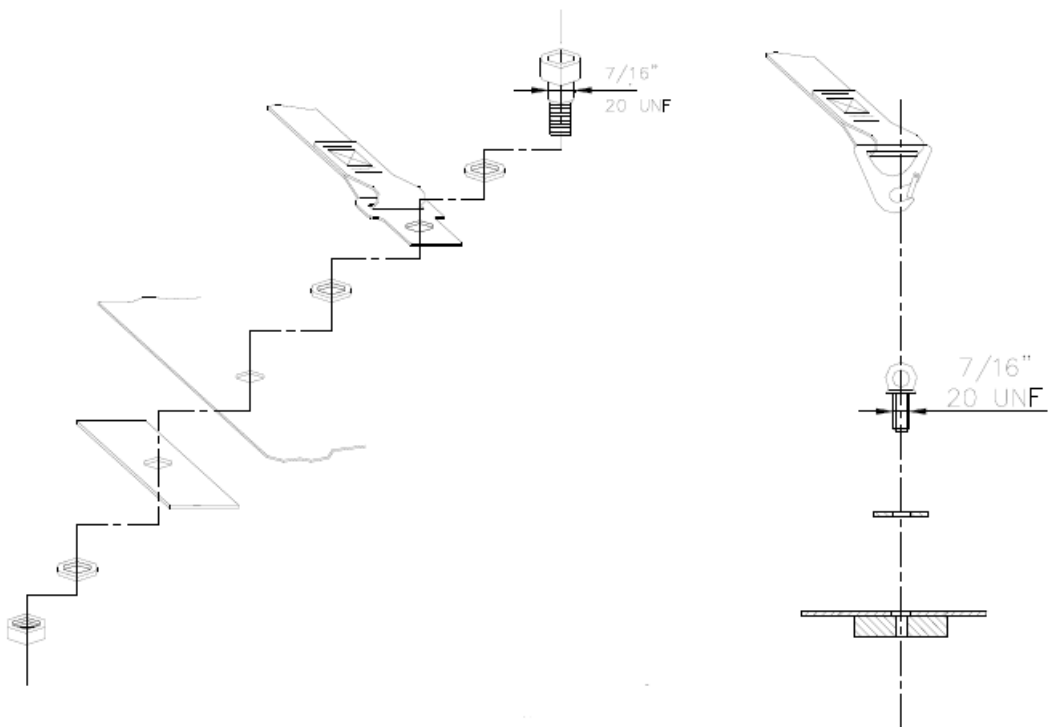

K-66

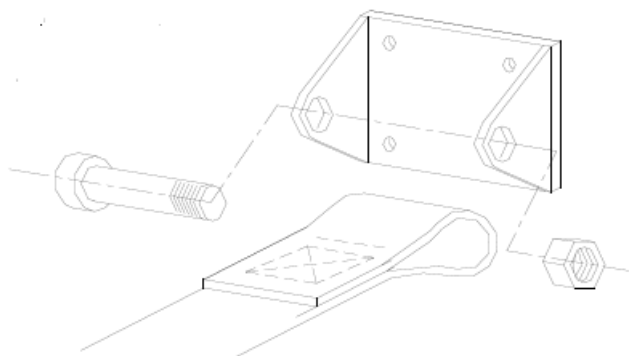

K-67

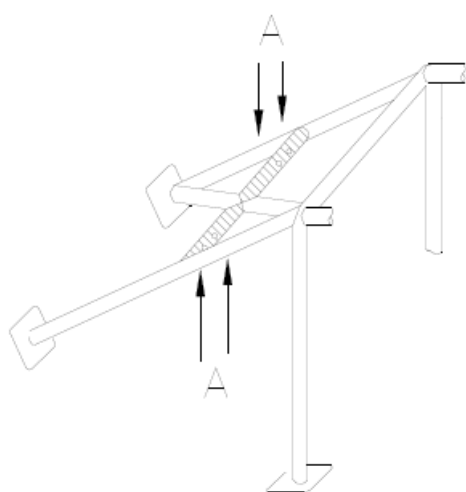
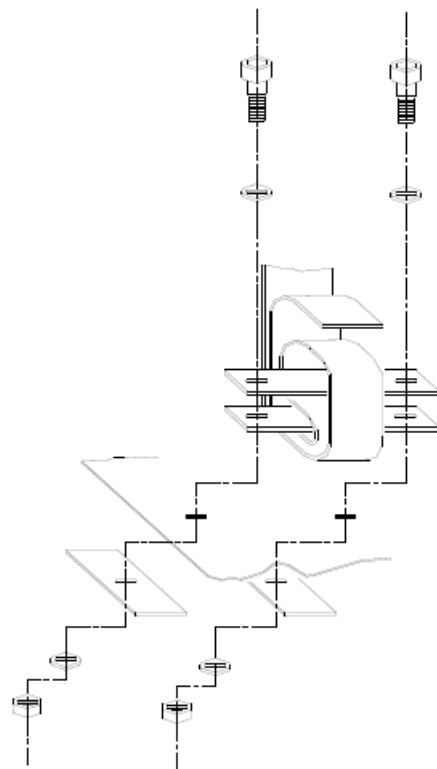

K-5

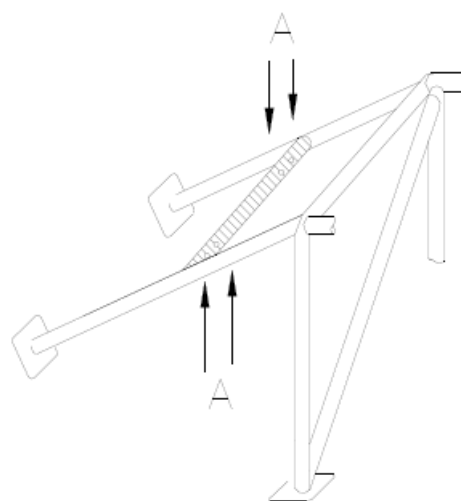

K-6

Furos de montagem para os cintos de segurança